

Range (D)	Effective Diameter (mm)	Nominal Base	TRUE Curve N=1.530	Back Curve	Center Thickness (mm)	Edge Thickness (mm)
+1.75 to +3.00	79	5.25	5.19	-5.50	12.7	12.9
-2.00 to +1.50	79	4.25	4.19	-5.50	11.6	13.3
-6.00 to -2.25	79	3.25	3.18	-5.50	15.2	17.5

Prescription Selection Chart

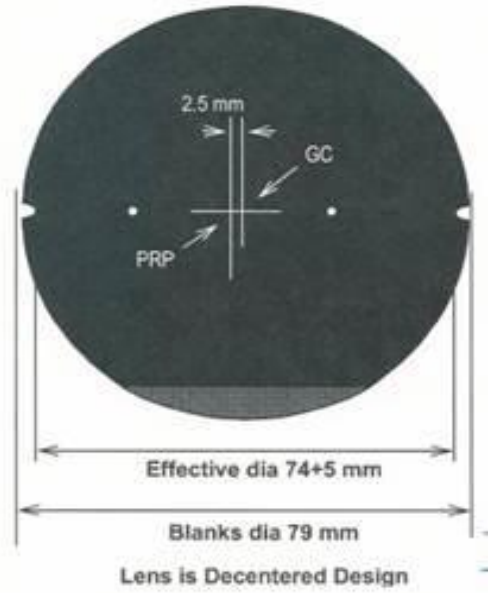
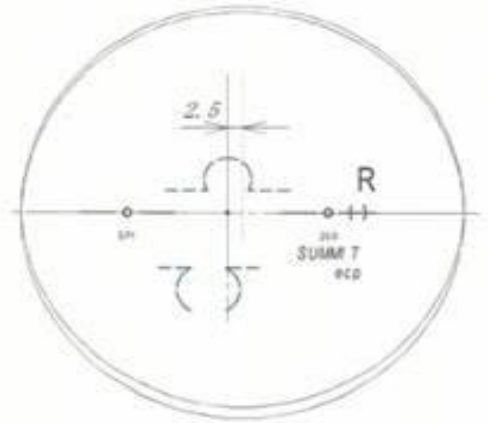
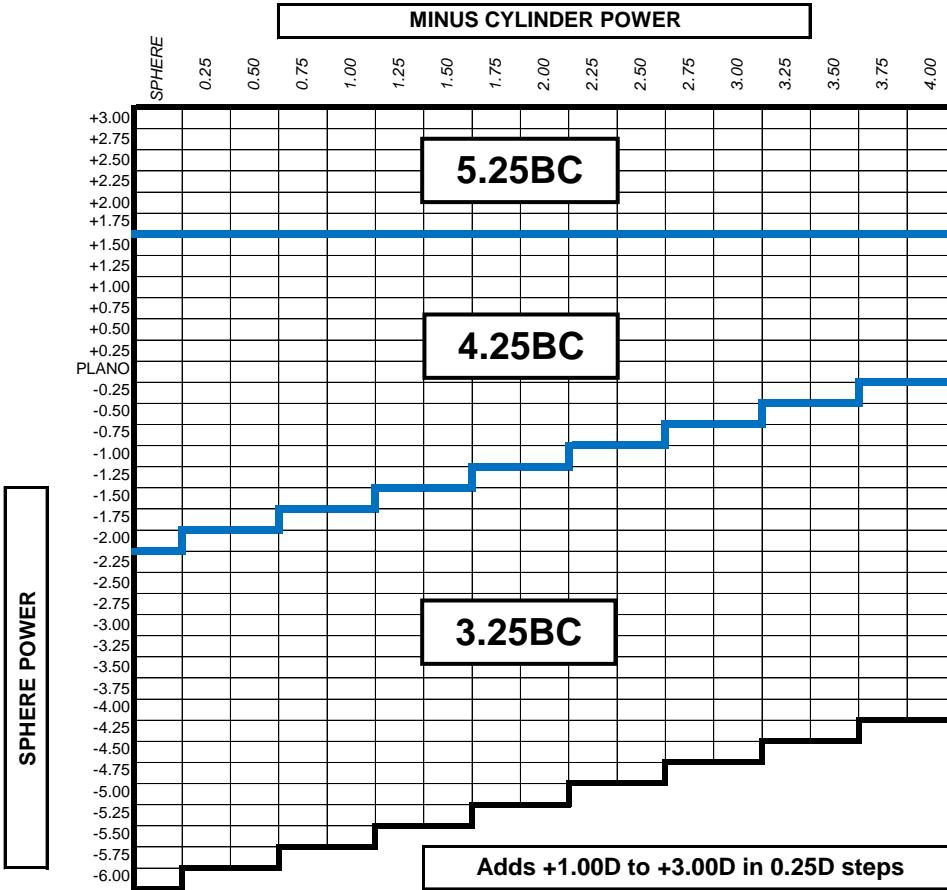

Fitting Height = 18mm min.